



Smart Architecture of Espadana  
Designing, Production, Customization and Consultant Service  
in Network and Fiber Optic System



### Technical Specification

**SAE-25GSD31-03**

25G SFP28 1310nm SM 300m DDM LC





## Product Description

- Supports 25Gbps data rate
- 1310nm DFB laser and PIN photo-detector
- Duplex LC receptacle optical interface compliant
- Single +3.3V power supply
- Power dissipation < 1.5W
- Hot-pluggable SFP28 form factor
- Internal CDR on both Transmitter and Receiver channel
- Maximum link length of 300m
- Operating temperature range: Commercial: 0<sup>o</sup> C~+70<sup>o</sup> C Industrial: -40~+85<sup>o</sup> C
- RoHS Compliant
- Digital diagnostics functions are available via the I2C interface

## Full Description

**SAE-25GSD31-03** SFP28 LR a single-Channel, Pluggable, Fiber-Optic SFP28 for 25 Gigabit Ethernet and Infiniband EDR Applications. It is a high performance module for short-range data communication and interconnect applications which operate at 25.78125 Gbps up to 300m.

This module is designed to operate over single mode fiber systems using a nominal wavelength of 1310nm. The electrical interface uses a 20 contact edge type connector.

The optical interface uses duplex LC receptacle. This module incorporates proven circuit and technology to provide reliable long life, high performance, and consistent service.

## Applications

- 25GBASE-LR Ethernet

## Technical specification

Absolute Maximum Ratings						
Parameter	Symbol	Min	Max	Unit		
Storage temperature	TS	-40	85	°C		
Power Supply Voltage	Vcc	0	3.6	V		
Relative Humidity	RH	5	95	%		
Recommended Operating Conditions						
Parameter	Symbol	Min	Typical	Max	Unit	
Operating Case Temperature (Commercial)	Tc	0		70	°C	
Operating Case Temperature (Industrial)	Tc	-40		85	°C	
Power Supply Voltage	Vcc	3.13	3.3	3.47	V	
Supply Current	Icc			450	mA	
Data Rate		-	25.78	-	Gbps	
Optical transmitter Characteristics						
Parameter	Symbol	Min	Typical	Max	Unit	Notes
Launched Power (avg.)	Pout	-7		2	dBm	
Operating Wavelength Range	$\lambda_c$	1290	1310	1330	nm	
Spectral Width (-20dB)	$\sigma$			1	nm	
Extinction Ratio	ER	4			dB	
Side Mode Suppression Ratio	SMSR	30			dB	
Differential data input swing	VIN,PP	180		700	mV	
Input Differential Impedance	ZIN	90	100	110	$\Omega$	
TX Disable	Disable	2.0		Vcc	V	
	Enable	0		0.8	V	
TX Fault	Fault	2.0		Vcc	V	
	Normal	0		0.8	V	
Output Eye Diagram	Complies with IEEE802.3z eye masks when filtered					

Optical receiver Characteristics							
Parameter		Symbol	Min	Typical	Max	Unit	Notes
Receiver Sensitivity		S			-10.5	dBm	
Stressed Sensitivity (OMA)			-	-	-6.8	dBm	
Wavelength Range		$\lambda_c$	1260	1310	1360	nm	
LOS	Optical De-assert	Pd			-12.5	dBm	
	Optical Assert	Pa			-13.5		
LOS		High	2.0		Vcc	V	
		Low			0.8	V	
LOS hysteresis			0.5			dB	
Differential data output swing		Vout,PP	300		900	mV	

Timing and Electrical					
Parameter	Symbol	Min	Max	Unit	Conditions
Tx-Disable assert time	T_off		100	us	Rising edge of Tx_Disable to fall of output signal below 10% of nominal
Tx-Disable negate time	T_on		2	ms	Falling edge of Tx_Disable to rise of output signal above 90% of nominal, this is only applies in normal operation, on during start up or fault recovery.
Time to initialize 2-wire interface	t_2w_start_up		300	ms	From power on or hot plug after the supply meeting
Time to initialize	T_start_up		300	ms	From power supplies meeting hot plug or Tx disable negated during power up, or Tx_Fault recovery, until non-cooled power level I part is full operational
Time to initialize cooled module and time to power up a cooled module to power level II	T_start_up_cooled		90	S	From power supplies meeting hot plug or Tx disable negated during power up, or Tx_Fault recovery, until non-cooled power level I part is full operational. Also, from stop bit low-to-high SDA transition enabling Power Level II until cooled module is fully operational.
Time to Power up to level II	T_power_level2		300	ms	From stop bit low-to-high SDA transition enabling power Level II until non-cooled module is fully operational.
Time to Power Down from level II	T_power_down		300	ms	From stop bit low-to-high SDA transition disabling power level II until module is within power level I requirements.
Tx_Fault assert	Tx_Fault_on		1	ms	From occurrence of fault to assertion of Tx_Fault.
Tx_Fault assert for cooled module	Tx_Fault_on_cooled		50	ms	From occurrence of fault to assertion of Tx_Fault.
Tx_Fault Reset	T_reset	10		us	Time Tx_Disable must be held high to reset Tx_Fault.

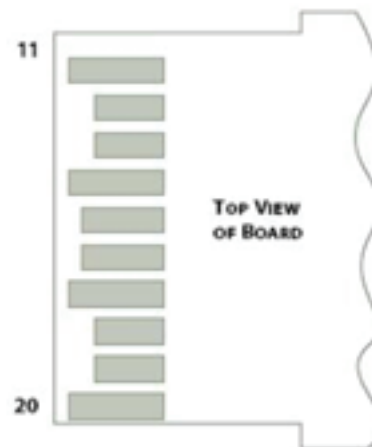
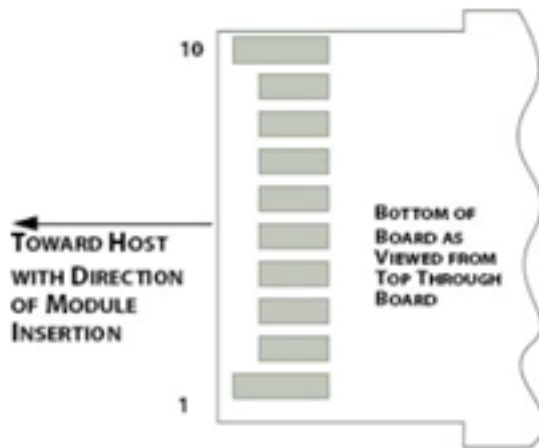
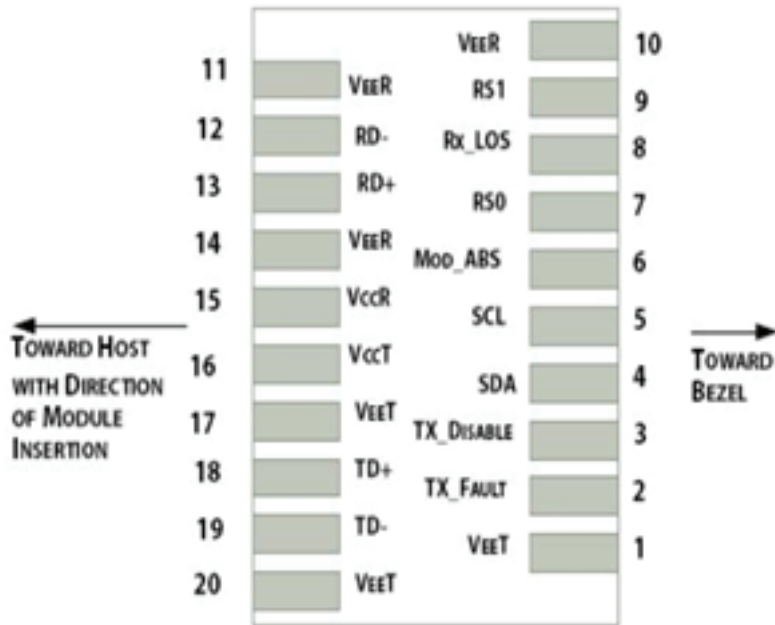

## Timing and Electrical

Pin	Name	Function/Description	Logic	Note
1	VeeT	Transmitter Ground		1
2	TX_Fault	Transmitter Fault	LVTTL-O	2
3	TX_Disable	Transmitter Disable. High: Transmitter off; Low: Transmitter on	LVTTL-I	
4	SDA	2-Wire Serial Interface Data Line	LVTTL-O/I	2
5	SCL	2-Wire Serial Interface Clock	LVTTL-I	2
6	Mod_ABS	Module Absent, Connect to VeeT or VeeR in Module		
7	RS0	Rate Select 0, optionally controls SFP module receiver	LVTTL-I	
8	RX_LOS	Receiver Loss of Signal indication. High: loss of signal; Low: signal detected	LVTTL-O	
9	RS1	Rate Select 1, optionally controls SFP module transmitter	LVTTL-I	
10	VeeR	Receiver Ground		1
11	VeeR	Receiver Ground		1
12	RD-	Receiver Inverted Data Output	CML-O	
13	RD+	Receiver Data Output	CML-O	
14	VeeR	Module Receiver Ground		1
15	VccR	Receiver Power 3.3V Supply		
16	VccT	Transmitter Power 3.3V Supply		
17	VeeT	Module Transmitter Ground		1
18	TD+	Transmitter Non-Inverted Data Input	CML-I	
19	TD-	Transmitter Inverted Data Input	CML-I	
20	VeeT	Module Transmitter Ground		1

RSO,RSI rate select timing for FC	T_RSO_FC,T_RSI_FC		500	us	From assertion till stable output
RSO,RSI rate select timing non FC	T_RSO,T_RSI		24	ms	From assertion till stable output
Rx_LOS assert delay	T_los_on		100	us	From occurrence of loss of signal to assertion of Rx_LOS
Rx_LOS assert delay	T_los_off		100	us	From occurrence of loss of signal to negation of Rx_LOS

### Digital Diagnostic Monitoring Information:

Parameter	Accuracy	Calibration	Range
Temperature Commercial	±3°C	internal/ External	0~70°C
Temperature Industrial	±3°C	internal/ External	-40~85°C
Voltage	±3%	internal/ External	3.0 to 3.6 V
Bias Current	±10%	internal/ External	0 to 100 mA
TX Power	±3dB	internal/ External	-5 to 2.0 dBm
RX Power	±3dB	internal/ External	-10.6 to 0 dBm

### Digital Diagnostic Memory Map

The transceivers provide serial ID memory contents and diagnostic information about the present operating conditions by the 2-wire serial interface (SCL, SDA).

The diagnostic information with internal calibration or external calibration all are implemented, including received power monitoring, transmitted power monitoring, bias current monitoring, supply voltage monitoring and temperature monitoring.

The digital diagnostic memory map specific data field defines as following.

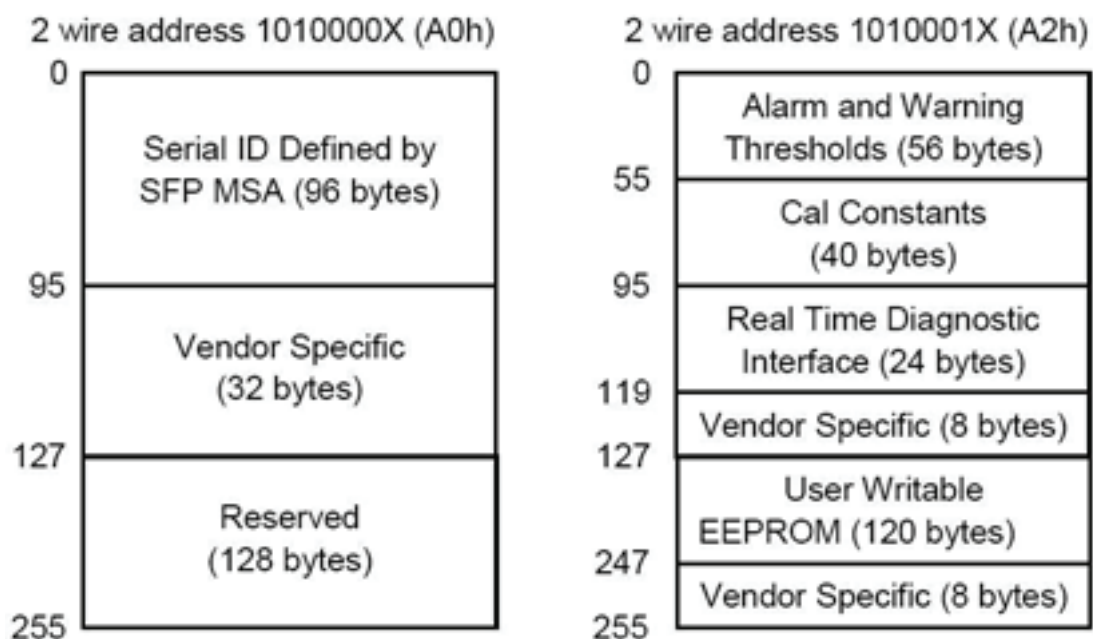

Product Size Display

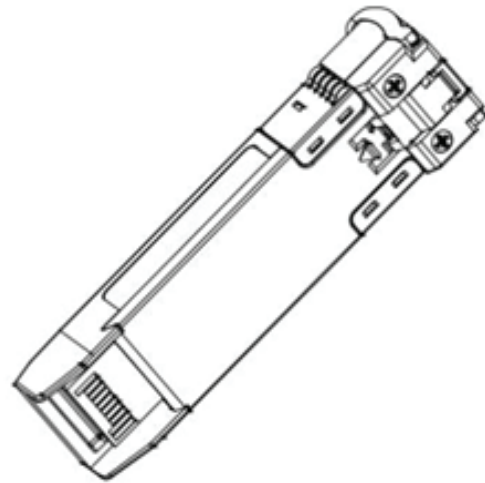
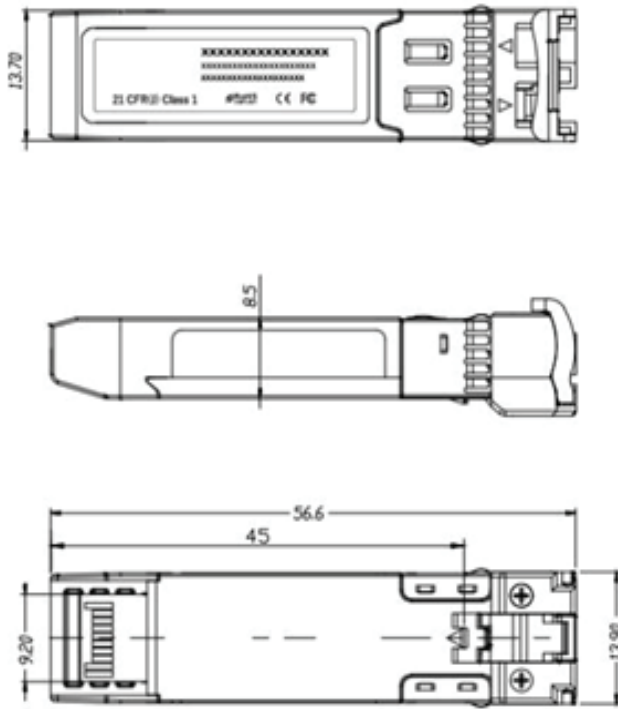

All dimensions are  $\pm 0.2$ mm unless otherwise specified.  
Unit: mm

Technical Specification of:  
**SAE-25GSD31-03**